

REV.	ECN NO.	LOCATIONS.	DESCRIPTION	DATE	CHANGER

**SPECIFICATIONS**

Pin Material: Brass/Tin-plated  
 Material: LCP  
 Color: Natural(Black)

**Ordering Code:**

TS302WR-F - XX X X

- ① Series No.
- ② No. of Contact: 04 to 50
- ③ Plating code:  
G=Gold Flash plated over  
1.27um(50u") Nickel
- ④ packing  
O=Box

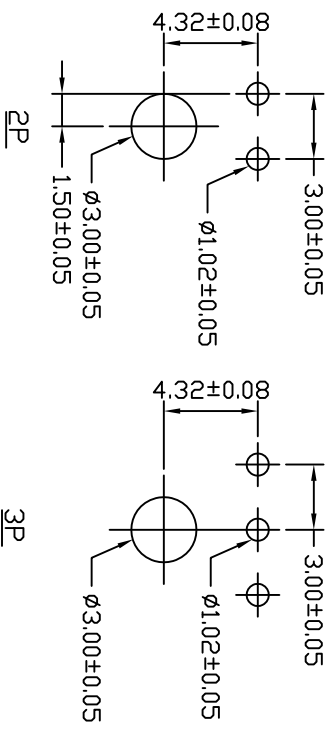
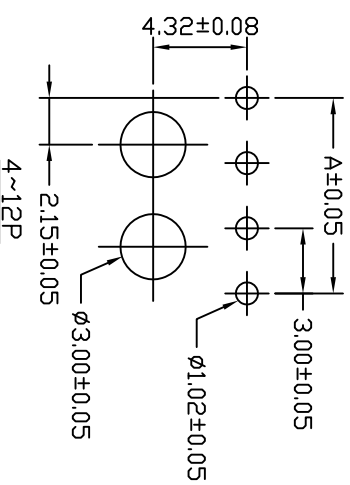
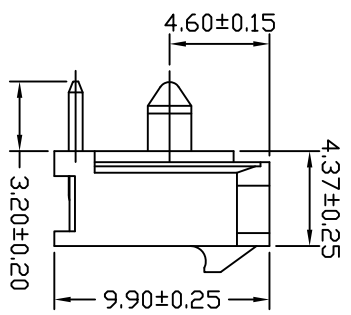
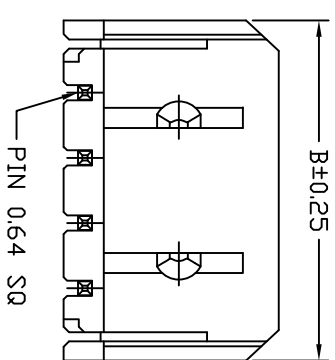
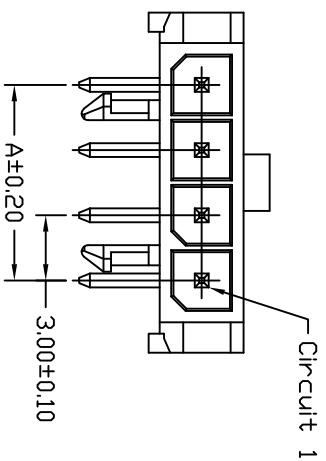
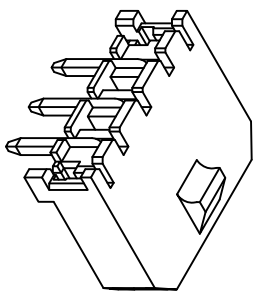

**P.C.B LAYOUT**

Ordering Information & Dimensions

PART NO.	Dimensions	
	A	B
TS302WR-F-0260	3.00	9.65
TS302WR-F-0360	6.00	12.65
TS302WR-F-0460	9.00	15.65
TS302WR-F-0560	12.00	18.65
TS302WR-F-0660	15.00	21.65
TS302WR-F-0760	18.00	24.65
TS302WR-F-0860	21.00	27.65
TS302WR-F-0960	24.00	30.65
TS302WR-F-1060	27.00	33.65
TS302WR-F-1160	30.00	36.65
TS302WR-F-1260	33.00	39.65

GENERAL TOLERANCE	
X±	X*± 1°
X± 0.25	X*±
XX± 0.15	XX*±
.XXX± 0.08	.XXX*±

**CUSTOMER DRAWING**

APPROVED	CHECKED:	DRAWN:	SCALE:	SHEET:
Paul	Paul	sunny	1:1	1 / 1

銳創科技有限公司

FRONTIER TECHNOLOGY CO., LTD.

TITLE: 3.00mm Single Row Water Dip Type Power Conn

PART NO.: TS302WR-F-XXXX  
 DWG NO.: 20130102